

# Blend Door vs. Mode Door Actuator

Because the blend door actuator and mode door actuator are typically located side by side and look nearly identical, it may be hard to distinguish which part you are replacing. Below is an example of an HVAC Unit Housing, from a 2010 Chevrolet Traverse. The HVAC Unit Housing is usually located under the dashboard on the passenger's side.

## Blend Door Actuator:

The blend door actuator is controlled by the vehicle's climate controls. The blend door can open and close at various positions to block or allow air passing through the heater core in order to achieve the desired temperature inside of the vehicle. The blend door actuator is typically located closer to the heater core and evaporator than the mode door.

## Mode Door Actuator:

The mode door actuator controls which vent(s) air blows through. The door on this actuator has two positions: closed and open.

Today, most actuators are controlled electronically. As actuators wear over time, the plastic gears inside may be stripped or broke, causing them to fail. A tell-tale sign of a faulty actuator is a clicking noise when the A/C system is on.

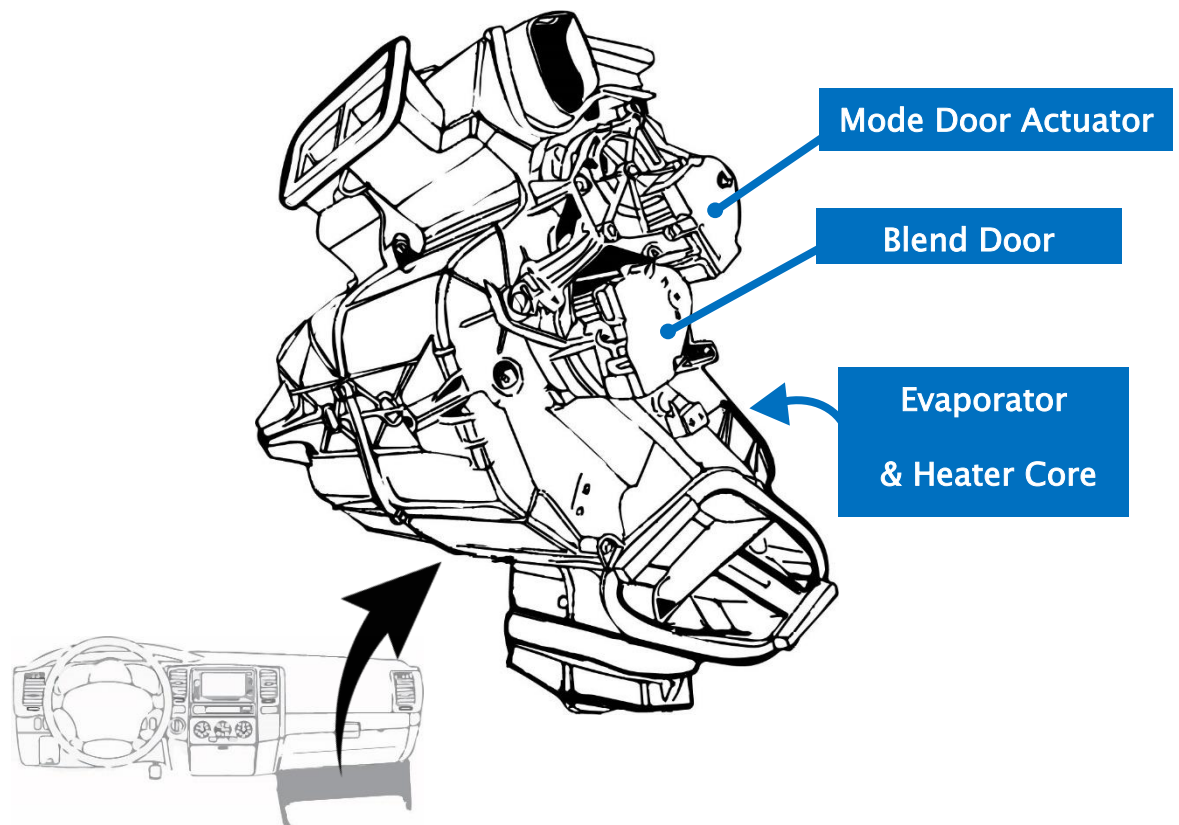

Manufacturer names, logos and part numbers are for reference only. All prices, taxes and availability are subject to change without notice. This document and any files transmitted with it are confidential and intended solely for the use of the individual or entity to which they are addressed. If you have received this document in error, please delete it immediately. Note that any views or opinions presented in this document are solely those of the author. Any unauthorized review, use, disclosure, or distribution is prohibited. Global Parts Distributors, LLC (gpd) accepts no liability for any damage caused by any virus or other means transmitted by this document. © Global Parts Distributors, LLC (gpd)

gpd.

Global Parts Distributors, LLC

TECH TIP

#140

gpdtechtips.com